

**ACCESSORI
ACCESSORIES
ZUSATZTEILE**

SUPPORTI TIRO CINGHIA

Per pompe e motori HP HYDRAULIC sono disponibili supporti tiro cinghia per azionamenti mediante cinghie o catene in cui sono presenti forti carichi radiali. Essi vengono flangiati direttamente a pompe e motori idraulici.

CHAIN STRETCHING SUPPORTS

Chain stretching supports are available for HP HYDRAULIC pumps and motors that are operate by belts or chain with high radial loads. They are directly flanged on to hydraulic pump or motor.

RIEMENSCHLEIBENKUPPLUNGEN

Für HP-HYDRAULIC Pumpen und Motoren sind Vorsatzlager, für den Antrieb mit Riemen oder Ketten mit starken Radialkräften, erhältlich. Diese werden direkt auf die Pumpen bzw. Motoren aufgefllanscht.

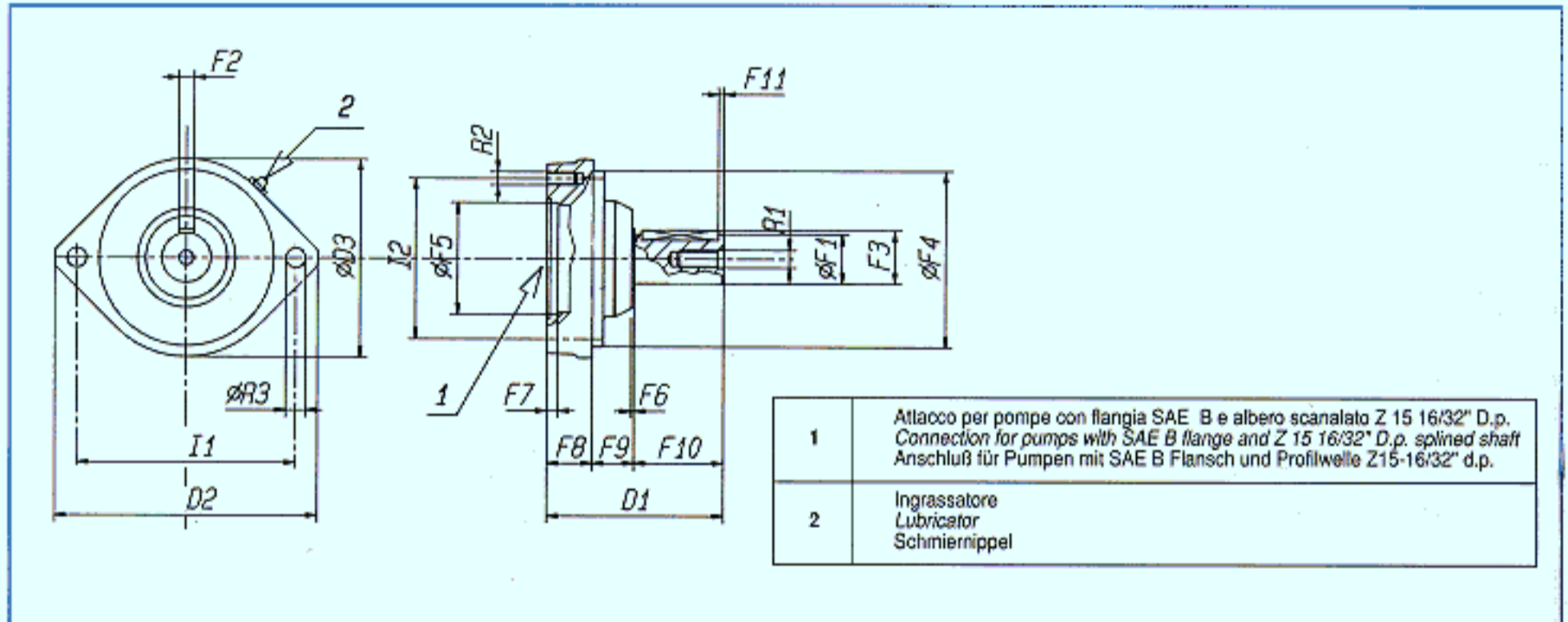

Dimensioni - Dimensions - Abmessungen

TIPO TYPE TYP	Ø F1	F2	F3	Ø F4	Ø F5	F6	F7	F8	F9	F10	F11	D1	D2	Ø D3	I1	I2	R1	R2	Ø R3
BS	35 1.38"	10 0.39"	38 1.50"	140 5.51"	101.6	3 0.12"	10	47.5 1.87"	32.5 1.28"	58 2.28"	4 0.16"	138 5.43"	212 8.35"	160 6.30"	180 7.09"	146	M12	M12	14 0.55"
BL	45 1.77"	14 0.55"	48.5 1.91"	160 6.3"	4"	2.5 0.10"	0.39"	42 1.65"	38 1.50"	82 3.23"	5 0.20"	161 6.34"	240 9.45"	180 7.09"	200 7.87"	5.75"	M16		18 0.71"

